

2300 Series

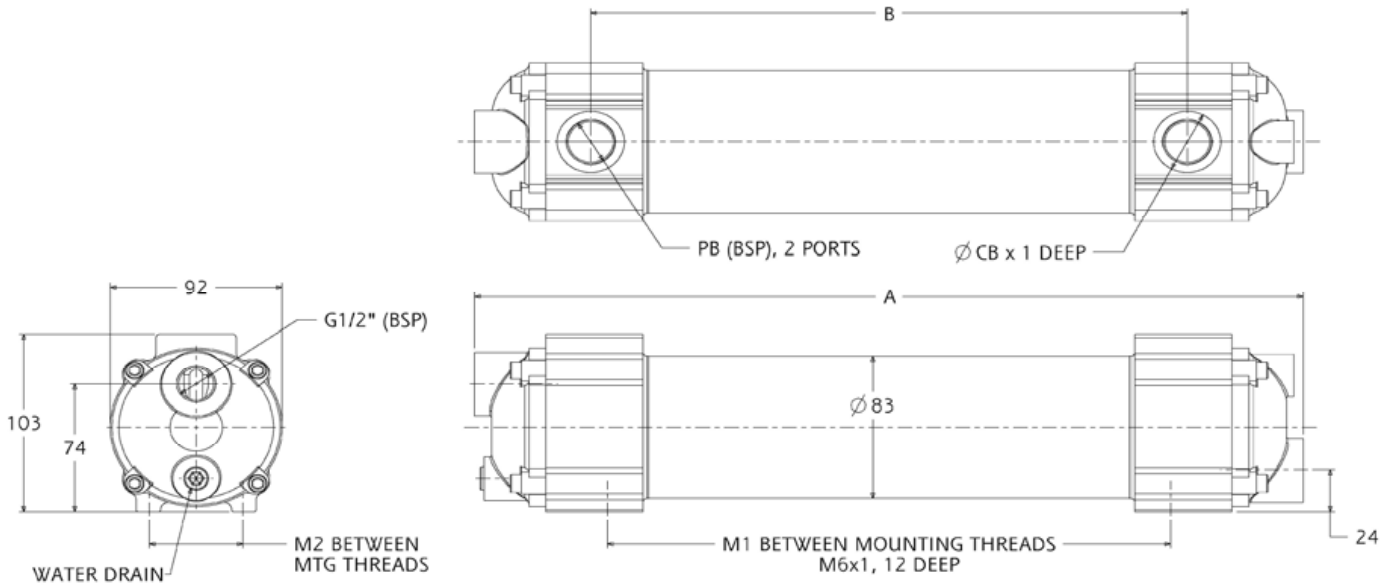

On model no 2310 two M6 x 12 mounting holes are provided on the base midway between the oil port centres.

Add suffix H to the Type Number for 3/4" BSP header connections.

Change last digit to 4 for Sea Water cooled (e.g. 2314, 2324)

Type	A	B	PB	ØCB	M1	M2	Kg	Oil Vol (l)	Water Vol (l)
2312	175	59	G 1/2"	29.1	-	50	3	0.3	0.4
2322	259	135	G 3/4"	36	117	50	4	0.5	0.5
2332	345	221	G 3/4"	36	203	50	5	0.7	0.6
2342	443	319	G 3/4"	36	301	50	5	1	0.7
2352	571	447	G 3/4"	36	429	50	6	1.3	0.9
2362	717	587	G 1"	-	575	50	7	1.7	1.1
2372	895	765	G 1"	-	753	50	8	2.2	1.4

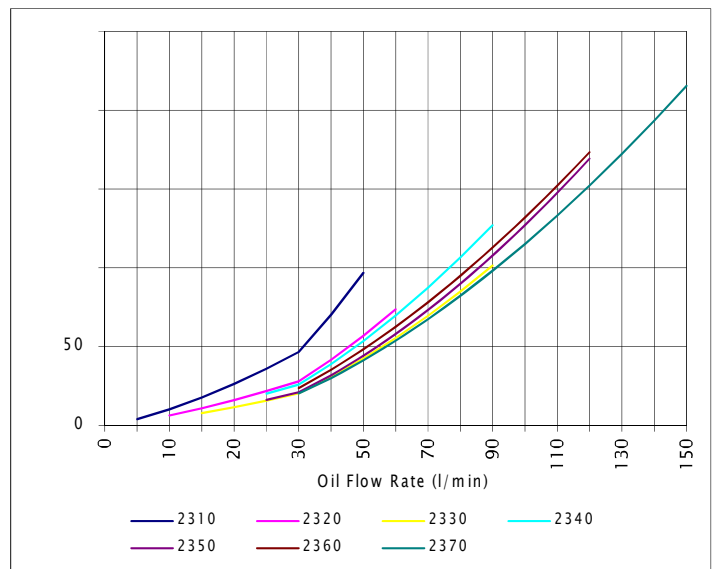
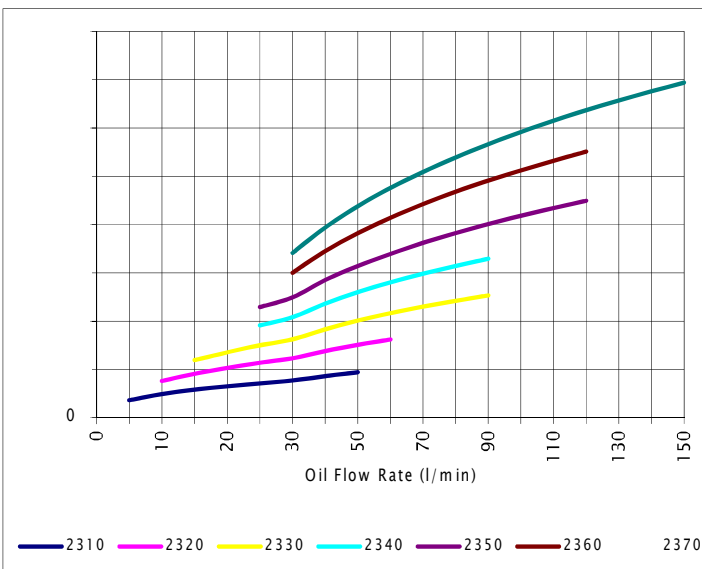

2500 Series

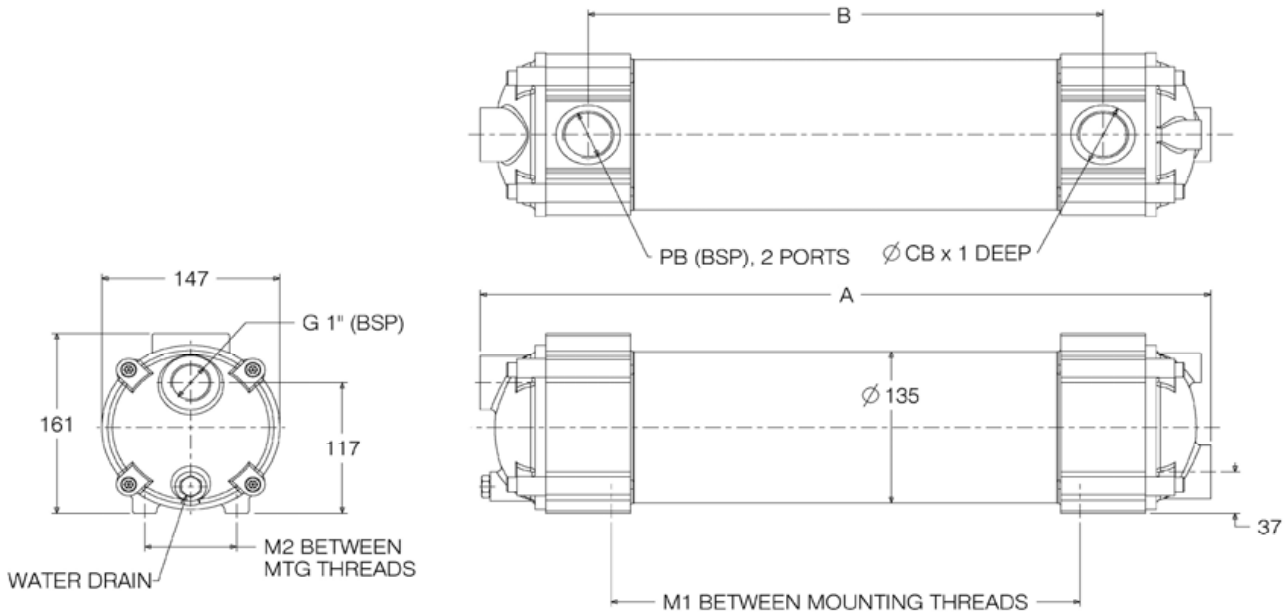

Add suffix H to the Type Number for 3/4" BSP header connections.

Change last digit to 4 for Sea Water cooled (e.g. 2514, 2524)

Type	A	B	PB	ØCB	M1	M2	Kg	Oil Vol (l)	Water Vol (l)
2512	291	129	G 1"	45	75	76	10	1.4	1.4
2522	377	199	G 1 1/4"	53	161	76	12	1.9	1.7
2532	475	297	G 1 1/4"	53	259	76	13	2.5	2.1
2542	603	425	G 1 1/4"	53	387	76	14	3.5	2.6
2552	749	571	G 1 1/2"	59	533	76	17	4.5	3.2
2562	927	749	G 1 1/2"	59	711	76	20	5.8	3.9
2572	1129	951	G 1 1/2"	59	913	76	23	7.3	4.8
2582	1381	1203	G 1 1/2"	59	1165	76	27	9	5.8
2592	1727	1549	G 1 1/2"	59	1511	76	32	11.5	7.2

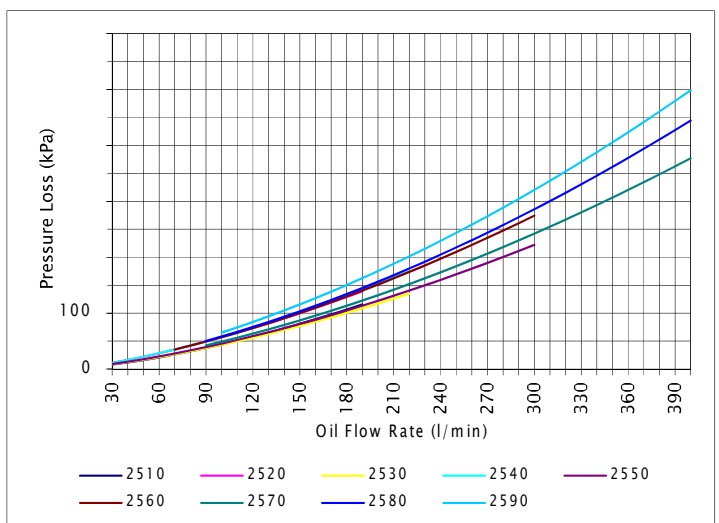
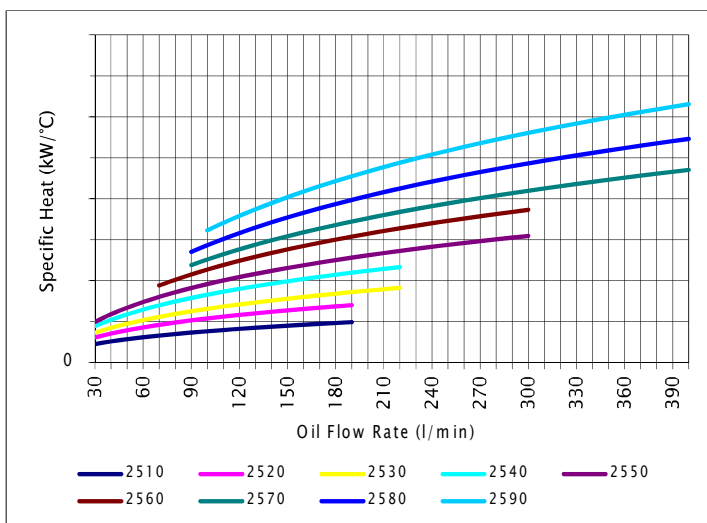

2700 Series

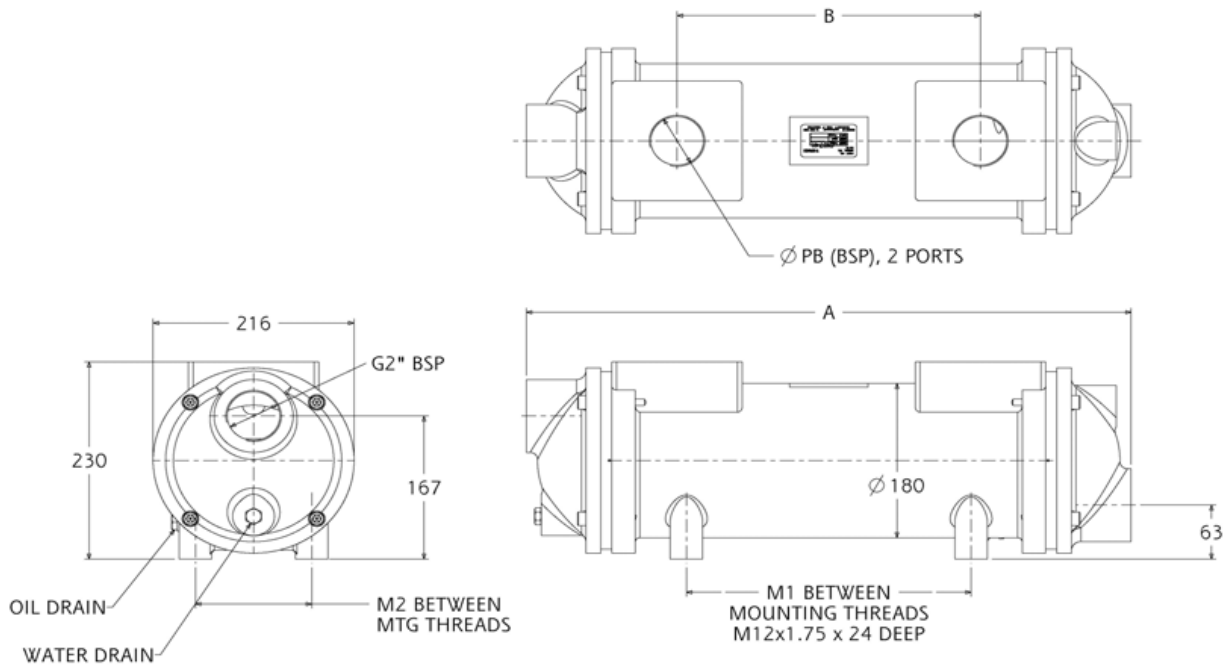

Change last digit to 4 for Sea Water cooled (e.g. 2714, 2724)

Type	A	B	PB	M1	M2	Kg	Oil Vol (l)	Water Vol (l)
2712	650	326	G 2"	306	125	38	5.5	5
2722	796	472	G 2"	452	125	43	7	6
2732	974	650	G 2"	630	125	48	9	7.5
2742	1176	852	G 2"	832	125	55	11	9
2752	1428	1104	G 2"	1084	125	63	14	10.5
2762	1777	1453	G 2"	1433	125	74	17.5	13

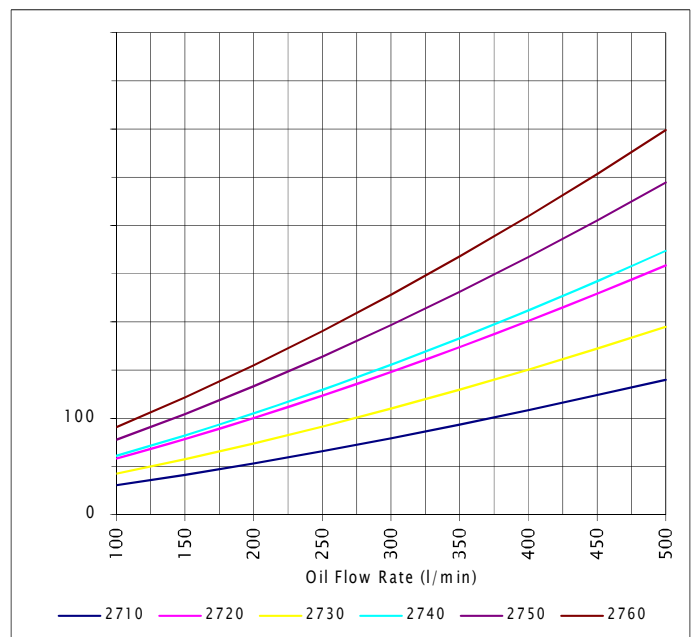
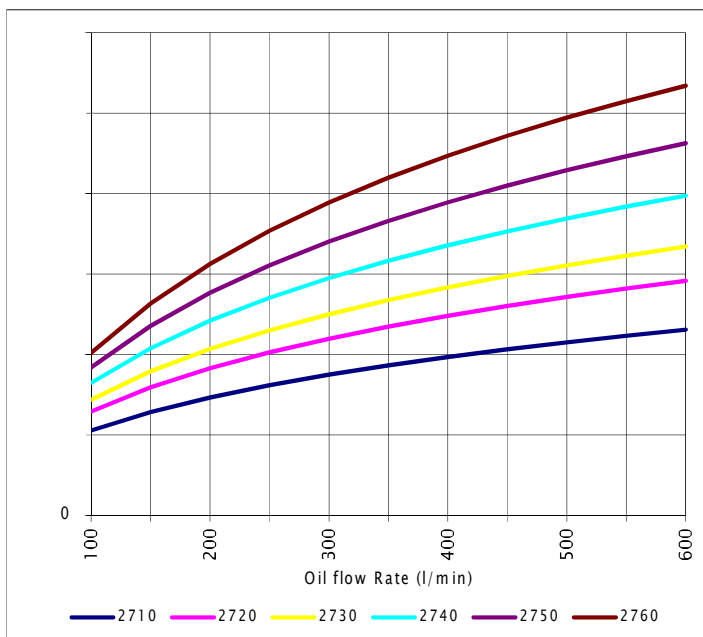

2800 Series

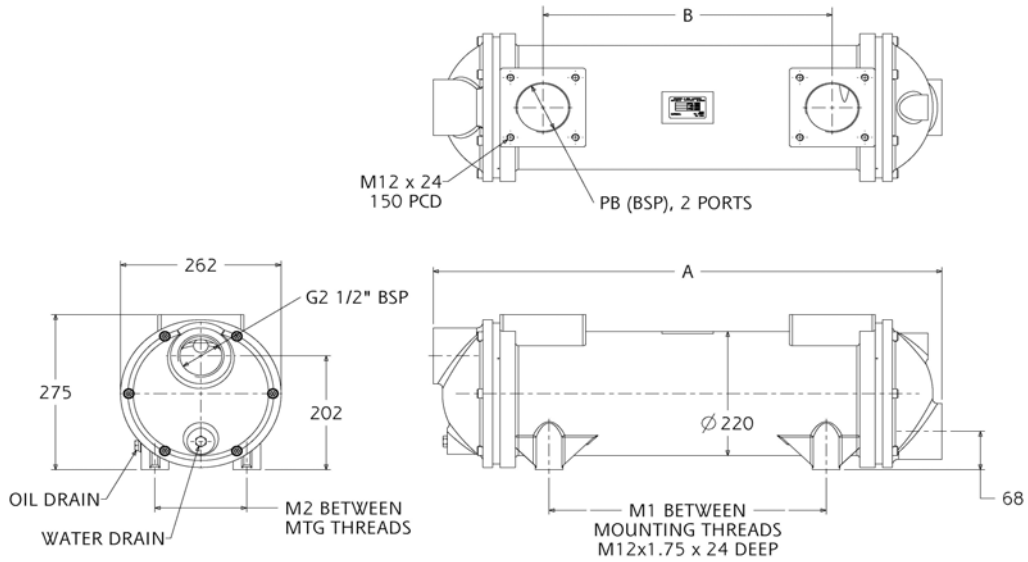

Change last digit to 4 for Sea Water cooled (e.g. 2814, 2824)

Type	A	B	PB	M1	M2	Kg	Oil Vol (l)	Water Vol (l)
2812	684	326	G 3"	306	150	48	9	7.5
2822	830	472	G 3"	452	150	54	11.5	9
2832	1008	650	G 3"	630	150	62	15	10.5
2842	1210	852	G 3"	832	150	71	18.5	13
2852	1462	1104	G 3"	1084	150	82	23	15.5
2862	1811	1453	G 3"	1433	150	97	29.5	19

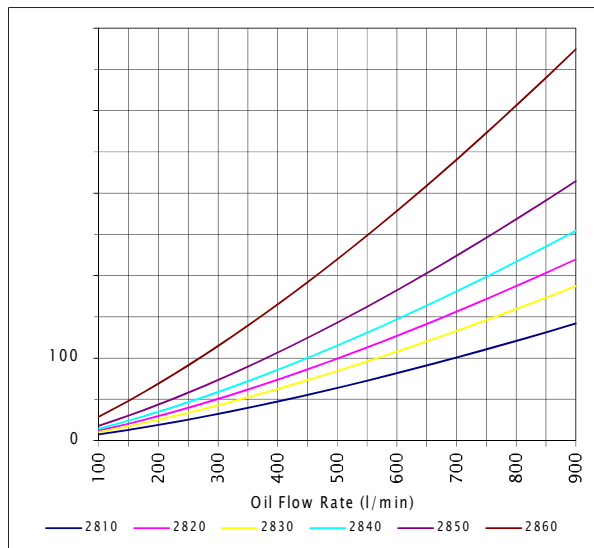
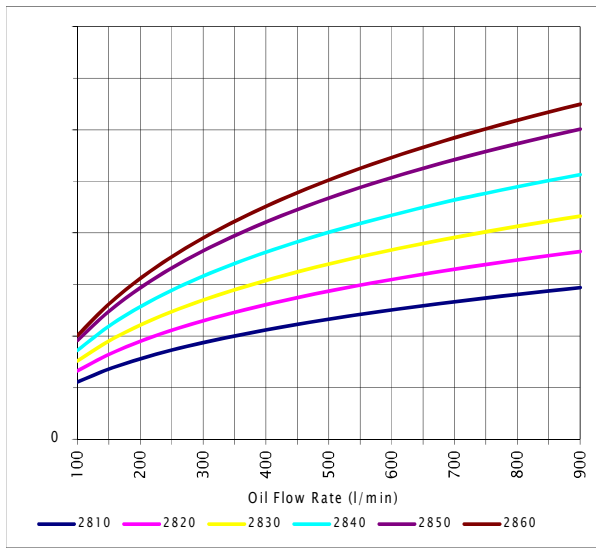

Fluid Dynamics
Heat Exchanger solutions since 1981



Head Office:
25-27 Star Crescent
Hallam Melbourne
Victoria 3803 Australia

T. (03) 9796 5988
F. (03) 9796 5777
E. mail@fluidynamics.com.au
W. www.fluidynamics.com.au



Local Dealer Network:

VIC (03) 9796 5988
NSW (02) 8073 7920
QLD (07) 3123 6684
WA (08) 6365 1790
SA (08) 7123 4203
TAS (03) 6107 9060
NT (08) 8967 1090
NZ (09) 972 1610